

WORLD MARKET®

Anti-Tip Measures

NAIRI FISH LARGE CABINET INDIGO

SKU - 598656



THANK YOU FOR YOUR PURCHASE. IF YOU HAVE ANY QUESTION
PERTAINING TO THE ANTI-TIP MEASURES, PLEASE CONTACT THE NEAREST
WORLD MARKET STORE.
IF YOU ARE NOT NEAR A STORE, PLEASE CALL OUR CUSTOMER SERVICE CALL
CENTER TOLL FREE AT 1-877-967-5362 FOR ASSISTANCE.

**ALL PRODUCTS SOLD AT WORLD MARKET
ARE NOT FOR COMMERCIAL USE AND ARE
INTENDED FOR RESIDENTIAL USE ONLY.**

Anti-Tip Kit

Warning - Children may be injured by tipping of furniture and the use of the Anti-Tip Kit is highly recommended. This Anti-Tip Kit is only a deterrent. It is not a substitute for proper adult supervision. Manufacturer and retailer assume no liability for improper installation or excess loads placed on screws, brackets, or straps. When properly installed, this restraint provides protection against unexpected tipping of furniture. This Anti-Tip Kit **MUST** be installed into the wall using proper mounting hardware OR into a wall stud using appropriate screws. Position of the Anti-Tip Kit depends on the product and the location of the wall studs. The hardware provided is not a comprehensive solution for all wall types. Be sure to consult a professional or your local hardware store to determine the hardware needed for your specific wall type (plaster, drywall, concrete, etc.).

Using a second person to assist you, place the unit in the desired final location against a wall. It is suggested to use a stud finder to find wall studs along the width of the unit and roughly 1 inch below the top of the unit. Where possible, mark a drill hole position on the wall where there is a stud and use a drill or screwdriver (**NOT INCLUDED**) to attach wall Brackets (A) to the wall using Long Screws (B) in the location of the wall studs.

In a case where there is no wall stud, hold Brackets (A) on wall and mark the drill hole positions so that they are roughly 1 inch below the top of the piece. Using a drill with a drill bit roughly the diameter of the plastic Wall Plugs (E), drill pilot holes in marked positions. Insert the plastic Wall Plugs (E) into the holes until the tops are roughly flush with the wall. Align the holes and insert the Long Screws (B) through Brackets (A) and into the corresponding holes in the wall using a phillips head screwdriver (**NOT INCLUDED**).

Next, attach remaining 2 Brackets (A) to the back of the piece using Short Screws (C) so they align with Brackets (A) installed on the wall. Loop Straps (D) through Brackets (A) on the furniture piece, then through Brackets (A) on the wall and tighten until snug. Installation is now complete.

IMPORTANT: Check that the Wall Bracket is firmly screwed into the wall and the Cable Tie is snug. If there is any hesitation, please consult a professional or your local hardware store.

A 4 x Bracket

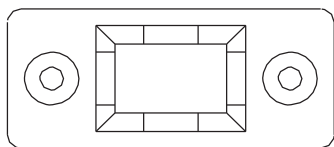

B 4 x Long Screw

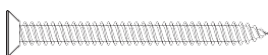

C 4 x Short Screw

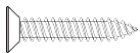

D Strap

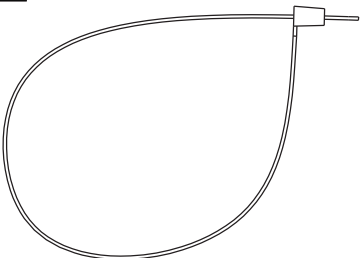

E 4 x Wall plug

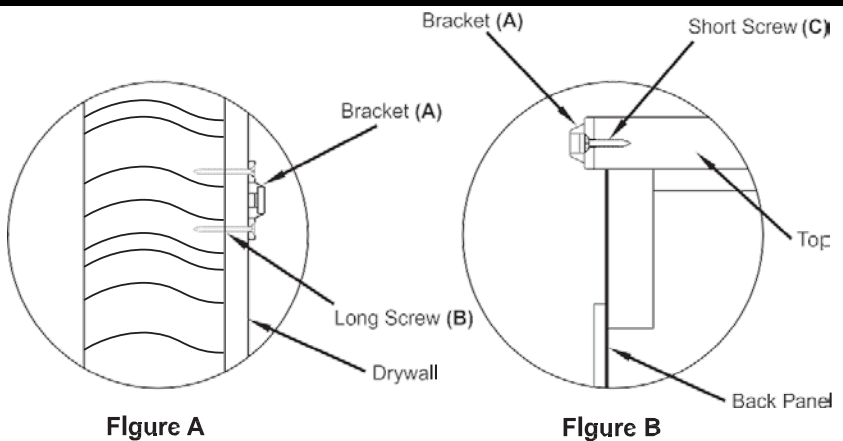

Figure A

Figure B

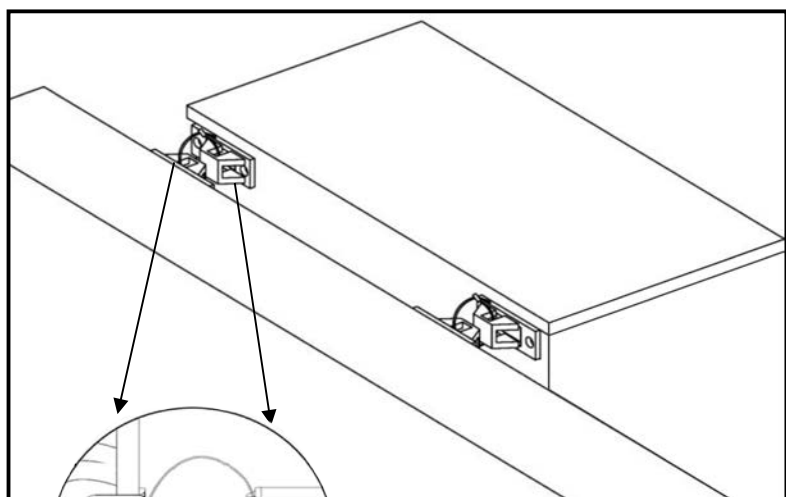
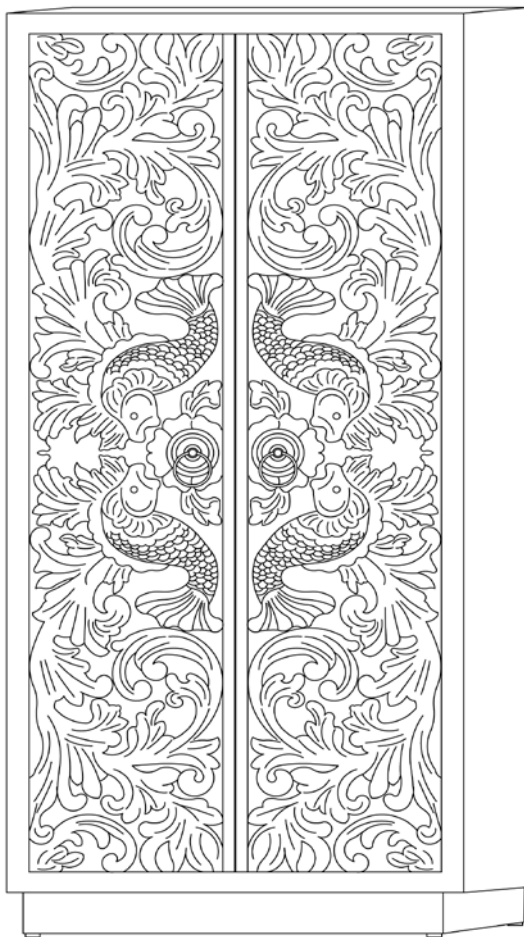



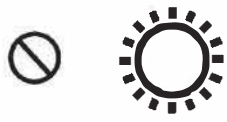



Figure C



LEVELERS CAN BE USED FOR ADJUSTMENT IF NEEDED .

⚠ WARNING	
	<p>Children have died from furniture tipover. To reduce the risk of furniture tipover:</p> <ul style="list-style-type: none">• ALWAYS install tipover restraint provided.• NEVER put a TV on this product.• NEVER allow children to stand, climb or hang on drawers, doors or shelves.• NEVER open more than one drawer at a time.• Place heaviest items in the lowest drawers.
	<p><i>This is a permanent label. Do not remove!</i></p>

Care & Maintenance

-  Do not put hot items directly on furniture surface.
-  Do not clean furniture with harsh cleansers or polish.
-  Do not place furniture in direct sunlight.
-  Do not place furniture near heating or cooling vents.
-  Do not write on furniture without a padded barrier to protect the surface.
-  Do not place furniture outside. For indoor use only.
-  All Products sold at World Market are not for commercial use and are Intended for residential use only.

-
-  Dust and pick-up spills using a clean, non-colored, lint-free cloth.



- WARNING:** Small parts are a choking hazard. Adult supervision is required before, during and after assembly.

WORLD MARKET LIMITED ONE-YEAR WARRANTY – Indoor Furniture

For your customer satisfaction, this product carries a LIMITED ONE-YEAR WARRANTY from the date of purchase. This limited warranty only applies to World Market brand furniture, and not to other furniture brands sold on World Market's website.

Where applicable, the limited warranty provides coverage for:

1. **Manufacturing, Material and Workmanship Defects:** Includes defects related to core frame/structure substrates (wood and metal); cracking, splitting, or complete breakage of hardwood, plywood or medium density fiberboard (MDF); cracking, splitting or lifting of wood veneer or laminated top surfaces caused by process failure; broken welds or improperly coated metal frame components (powder coating or painted); fabric or leather material defects including tears, misprints, fraying, crease marks, skip stitches or open seams; support webbing material and sinuous spring defects or damage, including method of attachment to frame; and other component failures that are a direct result of manufacturing or workmanship defects.
2. **Cushions & Cushions with Enclosed Steel Pocket Coils:** Failed or ruptured steel pocket coils enclosed inside of seat cushions, or loss of resiliency from a material breakdown of foam or fiber filling, which should not be confused with softening or settling during normal use.
3. **Leather:** Splitting or cracking of leather material. NOTE: The warranty does NOT cover natural hide markings, variations in the leather color or grain due to the authentic natural properties of processed cowhide leather.
4. **Bonded Leather or Bi-cast Leather:** Separation of the polyurethane coating, peeling or cracking of the inner layer or at the bonded seam edges (bi-cast straps).
5. **Furniture Components (Hardware & Mechanisms):** Includes defects to pre-installed components or hardware provided to the customer for assembly such as office chair hydraulic lifts, lift mechanisms, metal bases and casters, swivel plate mechanisms; for drawers, metal glides, handles/knobs; for doors, hinges, magnetic latches; and other components such as bent or stripped threaded leg posts and adjustable levelers. For missing, damaged, corroded, or misplaced hardware components such as bolts or washers, please contact Customer Service at: 877-967-5362.

This LIMITED ONE-YEAR WARRANTY does NOT cover:

1. Damage due to mishandling during transportation from store or transportation without original protective packaging.
2. Abuse, negligence (product misuse) or wear and tear that may result in or from:
 - a. **Wood & Veneer:** Mishandling, exposure to moisture, peeling or discoloration caused by exposure to moisture or excessive sunlight, heat; splintered, dented or nicked panels, legs or component edges or paint/finish blemishes; or treatment with corrosive chemicals (dyes, inks, paints or harsh cleaning products).
 - b. **Fabric & Leather (Including Bonded or Bi-Cast Leathers):** cuts, punctures, tears, burns, pet damage, or treatment with corrosive chemicals (dyes, inks, paints or harsh cleaning products), exposure to direct sunlight, fire, high heat, water, or any bright light source (natural or artificial) that may cause splitting, peeling or flaking with time.
 - c. **Foam (Cushions):** Flattening, relaxing or settling/softening of foam components that comes with normal use.
 - d. **Hardware Components:** improper installation or misuse/substitution of hardware components not defined in the Assembly Instructions for the product (if applicable)
3. Damage due to environmental exposure to direct sunlight, fire, high heat, water or extreme humidity, any bright light source (natural or artificial), or any environment that the product is not intended for.
4. This warranty is applicable for indoor furniture products purchased for residential use only.

For additional information on returns, please visit: <https://www.worldmarket.com/category/customer-service/returns.do>

All products sold at World Market are NOT FOR COMMERCIAL USE and are intended for residential use only. Products purchased for commercial use will VOID all warranty provisions as listed above.

Any claims under this LIMITED ONE-YEAR WARRANTY are valid and applicable only as to the original purchaser and must be accompanied by proof of purchase. Warranty claims should be submitted to a World Market store or through World Market Customer Service Call Center, Toll Free at 877-967-5362.

For valid warranty claims, World Market will repair or replace the product, or offer a full or partial credit, in the sole discretion of World Market. This LIMITED ONE-YEAR WARRANTY gives you specific legal rights and you may also have other rights which vary from state to state.

(INDOOR FURNITURE 1LW_v1.5_051122)